

# INSTRUCTIONS FOR INSTALLING "G" FOG LIGHT BRACKETS ON 1942 NASH STANDARD MODELS

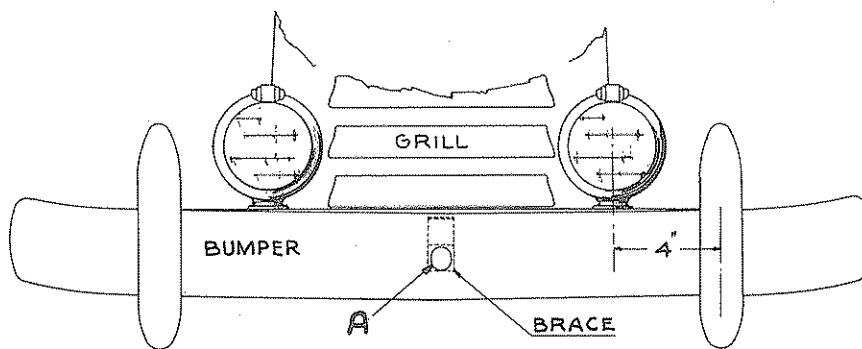

FIG. 1

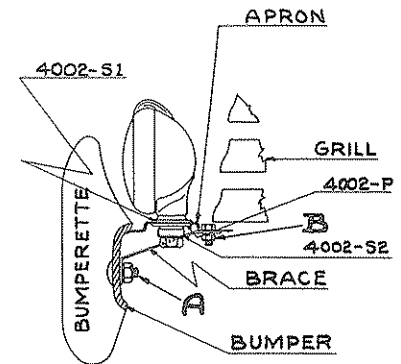

FIG. 2

1. Spot line on apron (Fig. 2) four inches (4") from bumper guard center line as indicated in Figure 1.
2. At center of this line, where it crosses raised head of apron, spot and drill  $\frac{1}{2}$ " hole. (See Figure 2).
3. Place part 4002-S1 on top of apron; Part 4002-P, Part 4002-S2 beneath apron. Place lock washer over bolt and push it through this bracket assembly. Then place the lamp over the bracket and screw the bolt into lamp shell bracket.
4. Remove nuts from bolts A (Figs. 1 and 2) and B (Fig. 2). Place brace (Nash Part 3119219) over bolts and replace the nuts, drawing up tightly. (See Figure 2).
5. Complete wiring installation and focusing of lamps in accordance with separate instruction sheet enclosed in lamp carton.

UNITY MANUFACTURING CO., 2909 Indiana Ave., CHICAGO, ILL.

