

INSTRUCTIONS FOR INSTALLING "D" FOG LIGHT BRACKETS  
ON 1941 PONTIAC

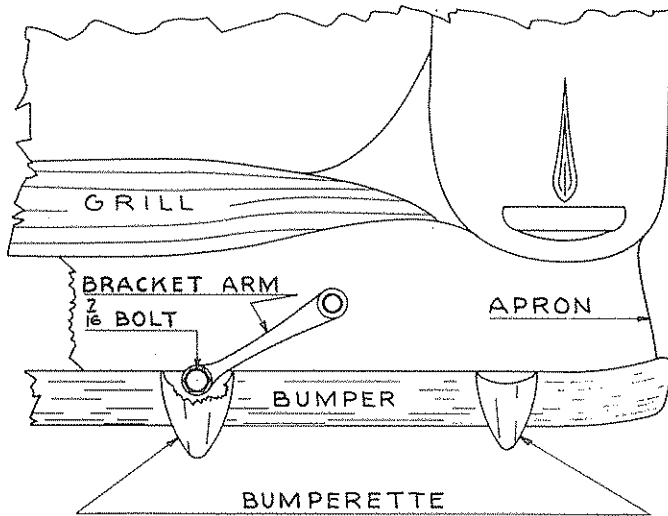

FIG. 1

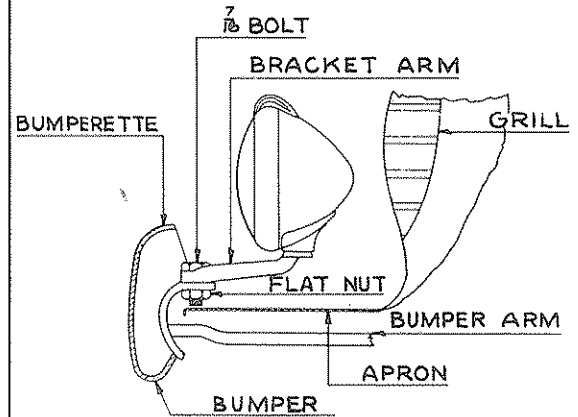

FIG. 2

1. Remove  $7/16$ " bolt 1" long, and flat nut from bumperette mounting close to the center of bumper as in Figure 1.

2. Place square hole, in bracket arm, over vacant hole and clamp down by screwing  $7/16$ " bolt  $1\frac{1}{2}$ " long, washer, and lock washer provided, into flat nut, Figure 2.

3. If pair of lamps is being installed, perform same operation on other bumperette close to the center of bumper.

4. Complete wiring and setting of lamps in accordance with instructions in enclosed sheet.

